



# GETTING READY FOR ALGEBRA 1

20 DIFFERENT SKILLS AND TOPICS THAT STUDENTS  
SHOULD BE PROFICIENT IN BEFORE ENTERING ALGEBRA I



# TABLE OF CONTENTS

PAGE	TOPIC
1	VARIABLES AND EXPRESSIONS
2	ORDER OF OPERATIONS
3	NUMBER PROPERTIES
4	EVALUATING EXPRESSIONS
5	ADDING & SUBTRACTING FRACTIONS
6	MULTIPLYING AND DIVIDING FRACTIONS
7	COMBINING LIKE TERMS
8	SOLVING ONE-STEP EQUATIONS
9	SOLVING TWO-STEP EQUATIONS
10	RATIOS
11	SOLVING PROPORTIONS
12	GRAPHING INEQUALITIES ON A NUMBER LINE
13	THE COORDINATE PLANE
14	GRAPHING BY MAKING A TABLE
15	SLOPE & $y$ -INTERCEPT OF A LINEAR EQUATION
16	BASIC EXPONENT RULES
17	SEQUENCES & PATTERNS
18	CALCULATING PERIMETER
19	CALCULATING AREA
20	PERFECT SQUARE NUMBERS

# VARIABLES & EXPRESSIONS

Translate each algebraic expression or verbal expression.

VERBAL EXPRESSION	ALGEBRAIC EXPRESSION
8 times a number $x$ is subtracted by 4	
	$6x^2 + 7$
5 increased by the product of -3 and a number $x$	
	$3x + 4y - 2$
3 times the sum of a number $x$ and 7	
	$\frac{x}{2} + 4x$
A number $y$ cubed plus $x$ squared decreased by 7	
	$5(x - 4) + 2$
the difference of $x$ and $y$ is divided by 3 and added by 8	
	$-2(x + 4)^2 - 1$

# ORDER OF OPERATIONS

Simplify each expression using the order of operations.

1. $5 - 6 + 2(3)$	2. $4 + 5(7 - 1) + \frac{8}{2}$
3. $-9(4 + 2) - 2(3) + 4^2$	4. $7 - 2[-6 - (3 + 1)] - \frac{8+7}{3}$
5. $0.5(-8 - 4) + 3(8 - 2^2)$	6. $3 - 5(2) - 7(5^2 - 4^2)$
7. $2(3)^2 - 4(3) + 1$	8. $4(3 - 5)^3 + 5$

# THE NUMBER PROPERTIES

---

Match each expression with the property that it shows.

$$5 + 0 = 5$$

Commutative Property  
of Addition

$$5(1) = 5$$

Associative Property  
of Addition

$$5(0) = 0$$

Additive Identity

$$2 + 3 = 3 + 2$$

Distributive Property

$$2(3) = 3(2)$$

Commutative Property  
of Multiplication

$$2 + (3 + 4) = (2 + 3) + 4$$

Associative Property  
of Multiplication

$$2(3 \cdot 4) = (2 \cdot 3)4$$

Zero Product Property

$$3(2 + 5) = 6 + 15$$

Multiplicative Identity

# EVALUATING EXPRESSIONS

Evaluate each expression given the following values for each variable.

$a = 2$	$b = -3$	$c = 4$	$d = -5$	$e = 6$	$f = -7$
---------	----------	---------	----------	---------	----------

1. $2a + 3d$	2. $b^2 - e^2$
3. $-3c - (a + d) + f$	4. $2(b - e) + (f + c)^2$
5. $\frac{d - c}{3} - 4(ab + f)$	6. $c(ab - 1) + de - f^2$

# ADDING & SUBTRACTING FRACTIONS

Add or subtract the fractions. Simplify your answer.

$$\frac{1}{2} + \frac{1}{2} =$$

$$\frac{1}{3} + \frac{1}{3} =$$

$$\frac{1}{4} + \frac{2}{4} =$$

$$\frac{2}{5} - \frac{1}{5} =$$

$$\frac{3}{6} - \frac{5}{6} =$$

$$\frac{1}{7} - \frac{8}{7} =$$

$$\frac{5}{8} - \frac{7}{8} =$$

$$-\frac{5}{9} - \frac{1}{9} =$$

$$-\frac{3}{10} + \frac{7}{10} =$$

$$\frac{1}{2} + \frac{5}{4} =$$

$$\frac{2}{9} + \frac{1}{3} =$$

$$\frac{1}{4} + \frac{2}{16} =$$

$$\frac{2}{3} - \frac{1}{5} =$$

$$\frac{3}{6} - \frac{5}{4} =$$

$$\frac{1}{2} - \frac{8}{7} =$$

$$\frac{5}{8} - \frac{7}{5} =$$

$$-\frac{5}{4} - \frac{1}{9} =$$

$$-\frac{3}{10} + \frac{7}{3} =$$

# MULTIPLYING & DIVIDING FRACTIONS

Multiply or divide the fractions. Simplify your answer.

$$\frac{5}{2} \cdot \frac{1}{2} =$$

$$\frac{1}{3} \cdot \frac{1}{3} =$$

$$\frac{1}{4} \cdot \frac{2}{4} =$$

$$-\frac{2}{5} \cdot \frac{3}{5} =$$

$$\frac{3}{6} \cdot -\frac{5}{6} =$$

$$-\frac{1}{4} \cdot -\frac{8}{7} =$$

$$4\left(\frac{5}{8}\right) =$$

$$-3\left(\frac{2}{3}\right) =$$

$$-2\left(\frac{4}{9}\right) =$$

$$\frac{1}{2} \div \frac{5}{4} =$$

$$\frac{2}{9} \div \frac{1}{3} =$$

$$\frac{1}{4} \div \frac{2}{5} =$$

$$-\frac{2}{3} \div \frac{1}{5} =$$

$$\frac{3}{6} \div -\frac{5}{4} =$$

$$-\frac{1}{2} \div -\frac{8}{7} =$$



# COMBINING LIKE TERMS

Combine like terms for each expression.

EXPRESSION	SIMPLIFIED
$x + x + 3x + y$	
$y + 2y + 5x + x$	
$5 + z + z + 4z - 6$	
$3x + 4x - 5$	
$5c + 2b - 3c$	
$x + y + 2x$	
$6a - 5b + a$	
$4 + 3x - 7 - 8x$	
$3(x + 2) - 4$	
$-5(x - 3) + 7x$	
$5m - 6n - 9m$	
$-8a - 9b - 10a + 9b$	
$2(x + 4) + 5x - 3$	
$-10(2 + x) - 3x$	

# SOLVING ONE-STEP EQUATIONS

---

Solve the one-step equations.

$$x + 7 = 9$$

$$5 + x = -3$$

$$6 = x + 8$$

$$x - 9 = 1$$

$$-5 + x = -2$$

$$4 = x - 7$$

$$5x = 75$$

$$-2x = -64$$

$$-7.5 = 1.25x$$

$$\frac{x}{4} = 7$$

$$-\frac{x}{2} = 8$$

$$-3 = -\frac{x}{9}$$

$$\frac{3}{4}x = 7$$

$$-\frac{1}{2}x = 8$$

$$-5 = -\frac{2}{9}x$$

# SOLVING TWO-STEP EQUATIONS

---

Solve the two-step equations. Leave your answer as a simplified fraction.

$$2x + 7 = 9$$

$$5 + 4x = -3$$

$$6 = 2x + 8$$

$$4x - 9 = 1$$

$$-5 + 3x = -2$$

$$4 = -x - 7$$

$$5x + 10 = 75$$

$$-2x + 8 = -64$$

$$-7.5 = 1.25x + 2.5$$

$$\frac{x}{4} - 6 = 7$$

$$-\frac{x}{2} + 3 = 8$$

$$-3 = 8 - \frac{x}{9}$$

$$\frac{3}{4}x + 5 = 7$$

$$-\frac{1}{2}x - 4 = 8$$

$$-5 = -\frac{2}{9}x + 2$$

# RATIOS

Create the ratios for each situation.

To create a perfect fruit smoothie for you and your friends, you must use 5 strawberries, 9 blueberries, 1 banana, 4 slices of pineapple, and 3 slices of mango.

FRUIT	RATIO
strawberries to blueberries	
strawberries to pineapple	
pineapple to mango	
mango to banana	
banana to blueberries	
mango to blueberries	
pineapple to berries	
mango to the smoothie	
pineapple to the smoothie	
berries to the smoothie	
berries to non-berries	
smoothie to blueberries	
smoothie to mango	

# SOLVING PROPORTIONS

---

Solve each proportion. Leave your answer as a simplified fraction or decimal.

$$\frac{x}{3} = \frac{4}{6}$$

$$\frac{6}{5} = \frac{x}{4}$$

$$\frac{3}{5} = \frac{6}{x}$$

$$\frac{x}{7} = \frac{1}{6}$$

$$\frac{6}{x} = \frac{2.5}{2}$$

$$\frac{4.5}{3} = \frac{9}{x}$$

$$\frac{x}{3} = \frac{4.2}{10}$$

$$\frac{11}{x} = \frac{2.5}{5.5}$$

$$\frac{6}{5} = \frac{12}{x}$$

# GRAPHING INEQUALITIES

Graph each inequality on the number line shown.

$x > 2$

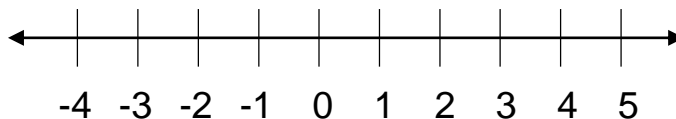

$x < -3$

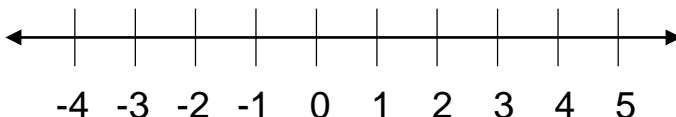

$x \geq -1$



$x \leq 4$

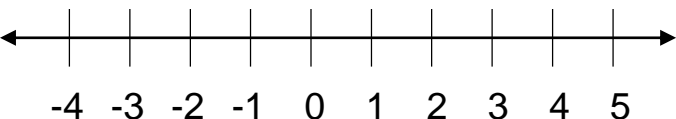

$x < 0$

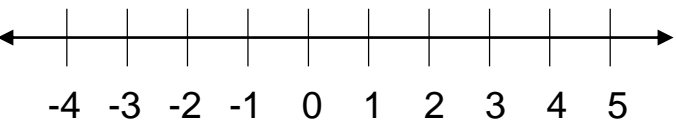

$x \geq 0$

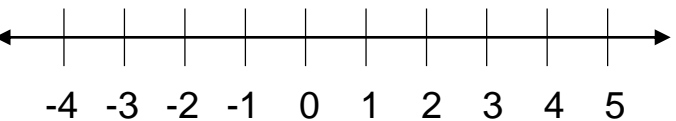

$x > -2$



# THE COORDINATE PLANE

Plot each point on the coordinate plane and name the quadrant the point is in.

POINT	QUADRANT
A(3, 4)	
B(5, -7)	
C(0, -5)	
D(-9, 2)	

POINT	QUADRANT
E(-1, -2)	
F(-8, 0)	
G(10, 3)	
H(-4, 8)	

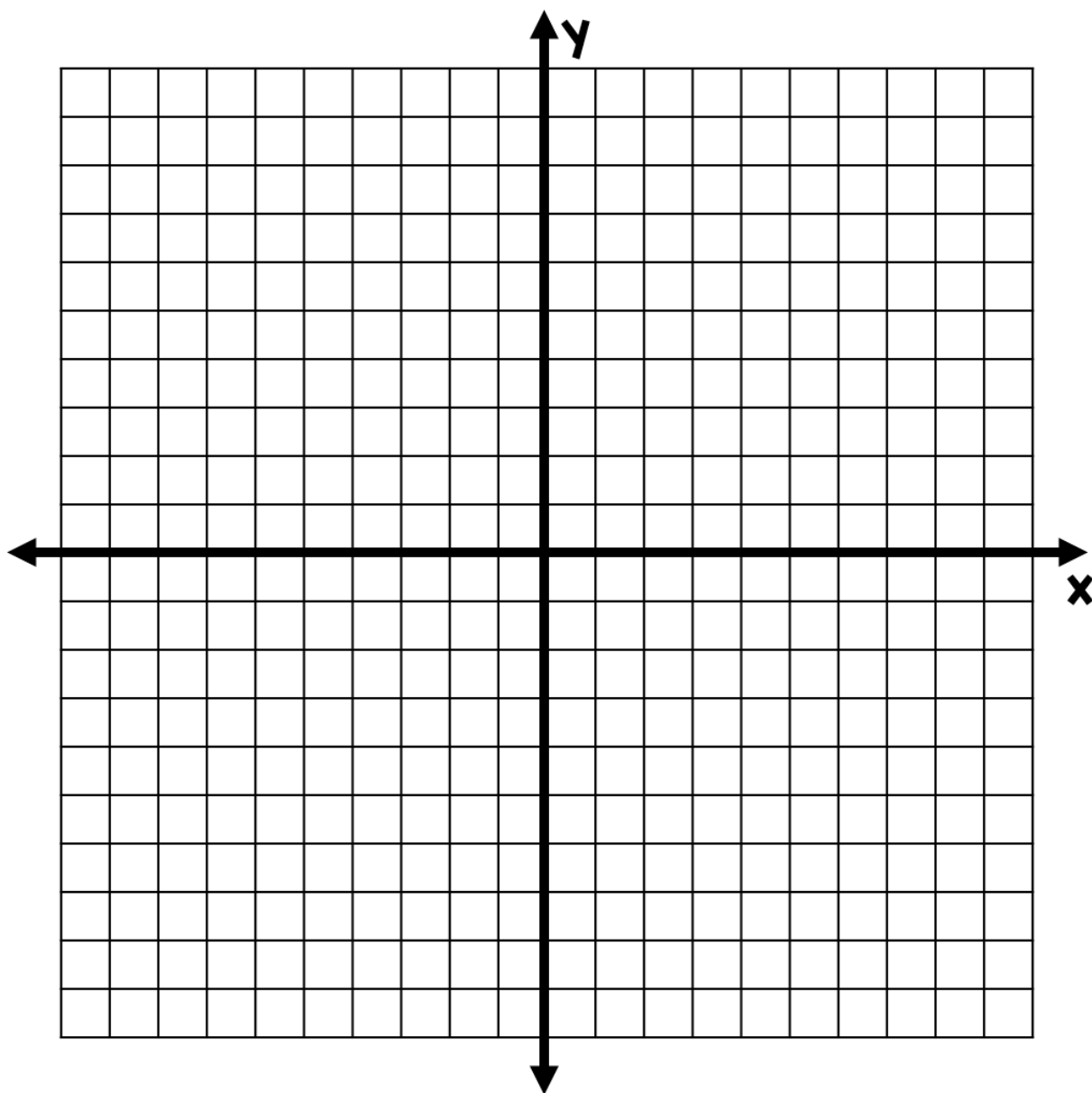

# GRAPHING BY MAKING A TABLE

Graph the equations by using substitution to complete a table of values.

$$y = x + 2$$

x	y
-2	
-1	
0	
1	
2	

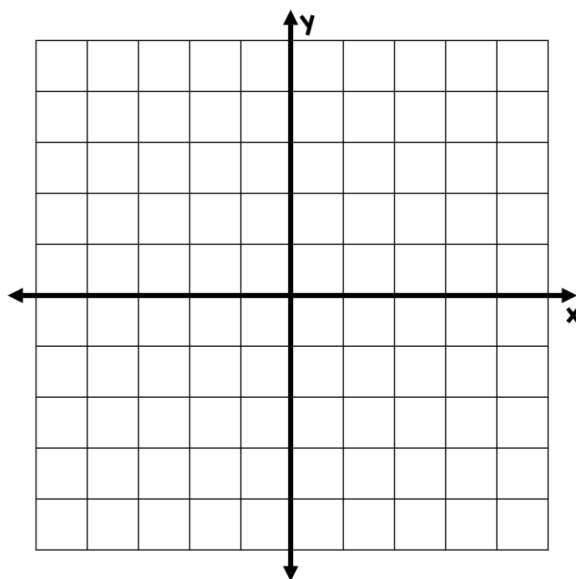

$$y = 2x - 1$$

x	y
-2	
-1	
0	
1	
2	

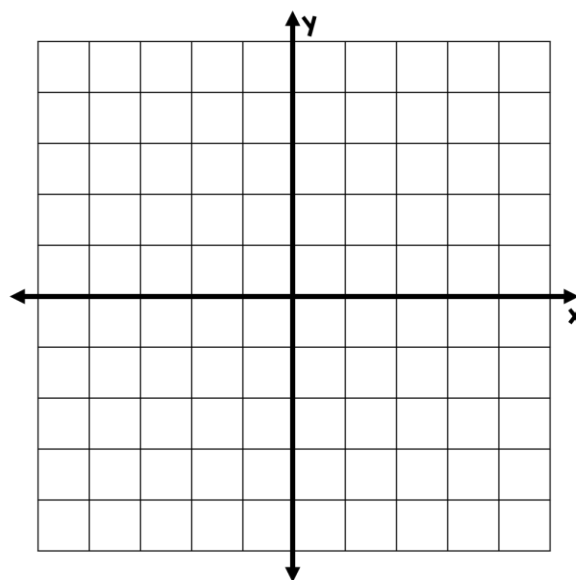



# SLOPE & $y$ -INTERCEPT

Determine the slope and the  $y$ -intercept of each graph.

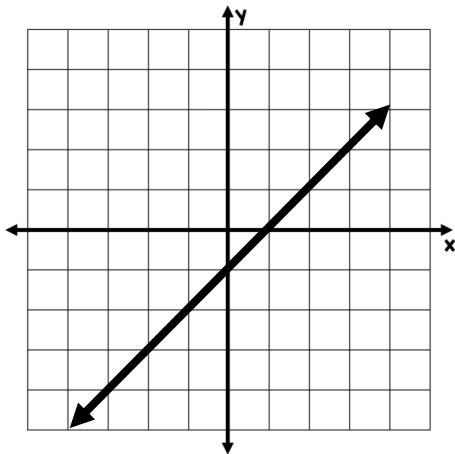

slope:	
$y$ -intercept:	

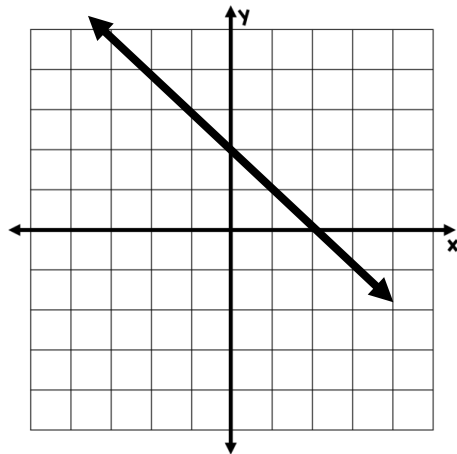

slope:	
$y$ -intercept:	

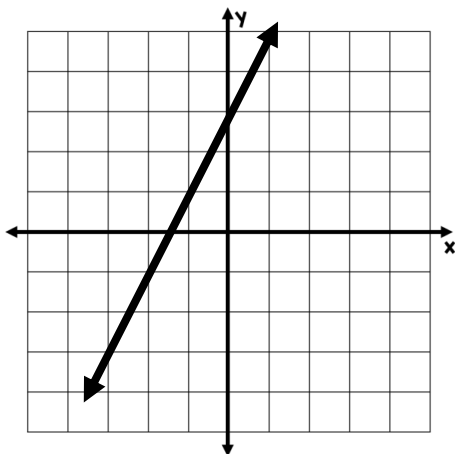

slope:	
$y$ -intercept:	

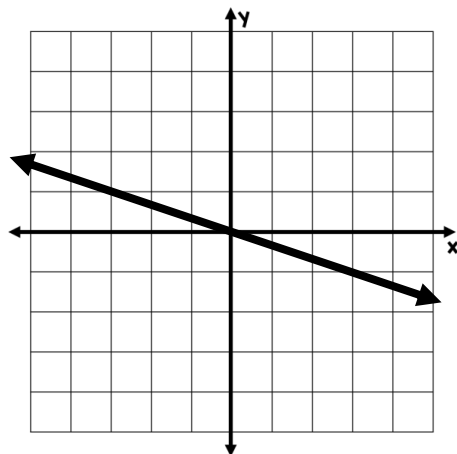

slope:	
$y$ -intercept:	

# BASIC EXPONENT RULES

Simplify each expression using exponent rules.

EXPRESSION	SIMPLIFIED
$x \cdot x$	
$y \cdot y \cdot y \cdot y$	
$x \cdot x \cdot y \cdot y \cdot y$	
$y \cdot z \cdot z \cdot z \cdot z \cdot z$	
$x^2 \cdot x^3$	
$x^5 \cdot x^4$	
$y^6 \cdot y$	
$(x^4)^3$	
$(y^3)^2$	
$x^2 \cdot x \cdot y^3 \cdot y^4$	
$a^4 \cdot b^8 \cdot a^5 \cdot b^2$	
$c^3 \cdot d \cdot c^4 \cdot b$	
$\frac{x^5}{x^2}$	
$\frac{y^8}{y^3}$	

# SEQUENCES & PATTERNS

Determine the pattern of each sequence and find the next 3 terms.

2, 4, 8, 16, 32, \_\_\_\_\_, \_\_\_\_\_, \_\_\_\_\_

5, 10, 15, 20, 25, \_\_\_\_\_, \_\_\_\_\_, \_\_\_\_\_

-5, -3, -1, 1, 3, \_\_\_\_\_, \_\_\_\_\_, \_\_\_\_\_

0.4, 0.2, 0, -0.2, -0.4, \_\_\_\_\_, \_\_\_\_\_, \_\_\_\_\_

3, -6, 12, -24, 48, \_\_\_\_\_, \_\_\_\_\_, \_\_\_\_\_

$\frac{3}{9}$ ,  $\frac{4}{9}$ ,  $\frac{5}{9}$ ,  $\frac{6}{9}$ ,  $\frac{7}{9}$ , \_\_\_\_\_, \_\_\_\_\_, \_\_\_\_\_

$\frac{1}{2}$ ,  $\frac{1}{4}$ ,  $\frac{1}{8}$ ,  $\frac{1}{16}$ ,  $\frac{1}{32}$ , \_\_\_\_\_, \_\_\_\_\_, \_\_\_\_\_

6, -3, -12, -21, -30, \_\_\_\_\_, \_\_\_\_\_, \_\_\_\_\_

2, 5, 12.5, 31.25, 78.125, \_\_\_\_\_, \_\_\_\_\_, \_\_\_\_\_

# CALCULATING PERIMETER

Determine the perimeter of each figure.

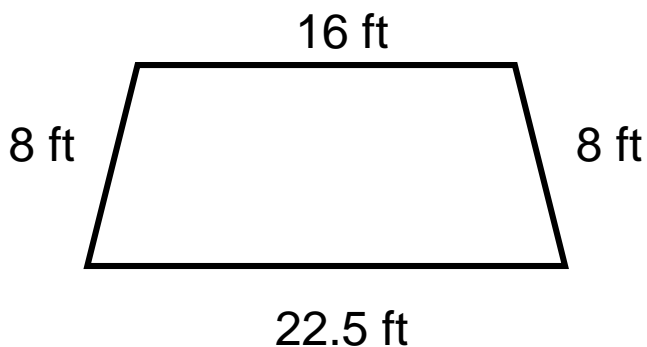

$P =$

$P =$

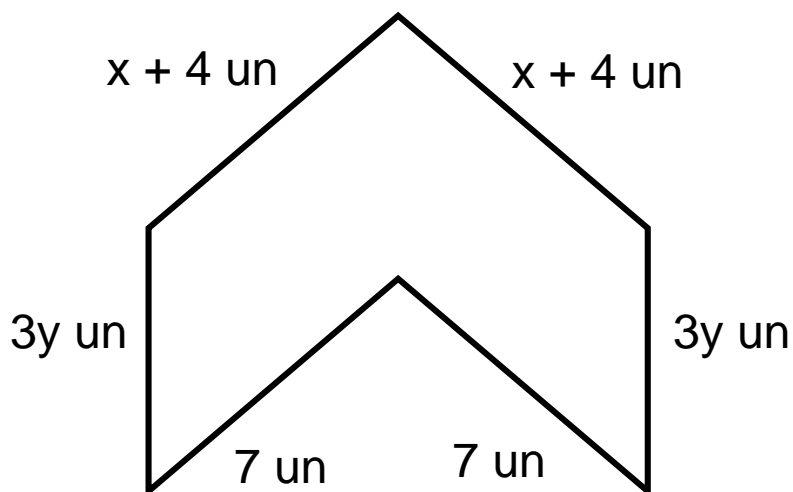
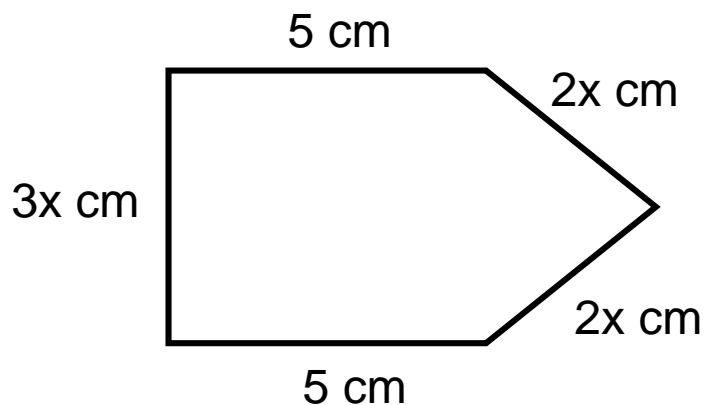

$P =$

# CALCULATING AREA

Determine the area of each figure.

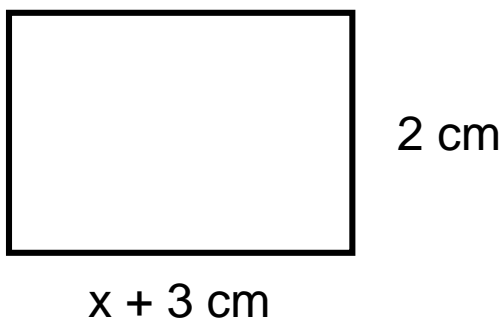

A =

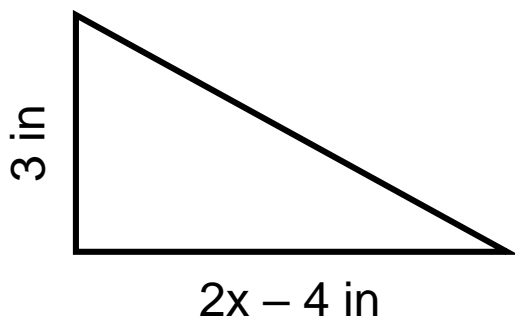

A =

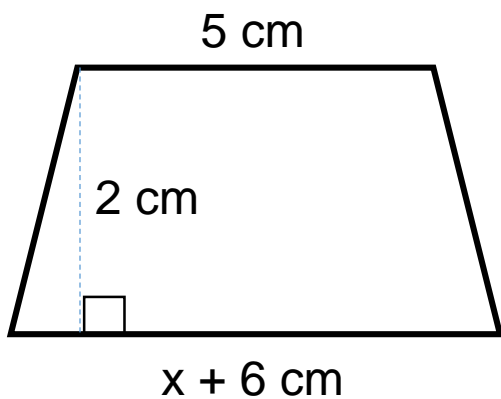

A =

# PERFECT SQUARE NUMBERS

Complete the perfect squares chart. Fill in as many as you can without a calculator.

$1^2 =$		$16^2 =$	
$2^2 =$		$17^2 =$	
$3^2 =$		$18^2 =$	
$4^2 =$		$19^2 =$	
$5^2 =$		$20^2 =$	
$6^2 =$		$21^2 =$	
$7^2 =$		$22^2 =$	
$8^2 =$		$23^2 =$	
$9^2 =$		$24^2 =$	
$10^2 =$		$25^2 =$	
$11^2 =$		$30^2 =$	
$12^2 =$		$40^2 =$	
$13^2 =$		$50^2 =$	
$14^2 =$		$60^2 =$	
$15^2 =$		$70^2 =$	

# ANSWER KEY

# VARIABLES & EXPRESSIONS

Translate each algebraic expression or verbal expression.

VERBAL EXPRESSION	ALGEBRAIC EXPRESSION
8 times a number $x$ is subtracted by 4	$8x - 4$
the product of 6 and a number $x$ squared is increased by 7	$6x^2 + 7$
5 increased by the product of -3 and a number $x$	$5 - 3x$
3 times the number $x$ plus 4 times the number $y$ is decreased by 2	$3x + 4y - 2$
3 times the sum of a number $x$ and 7	$3(x + 7)$
the quotient of $x$ and 2 is added by the product of 4 and $x$	$\frac{x}{2} + 4x$
A number $y$ cubed plus $x$ squared decreased by 7	$y^3 + x^2 - 7$
5 times the difference of $x$ and 4 is added by 2	$5(x - 4) + 2$
the difference of $x$ and $y$ is divided by 3 and added by 8	$\frac{x - y}{3} + 8$
negative 2 times the square of the sum of a number $x$ and 4 is subtracted by 1	$-2(x + 4)^2 - 1$



# ORDER OF OPERATIONS

Simplify each expression using the order of operations.

<p>1. <math>5 - 6 + 2(3)</math>  <math>5 - 6 + 6</math>  <math>-1 + 6</math>  <span style="border: 1px solid red; padding: 2px;">5</span></p>	<p>2. <math>4 + 5(7 - 1) + \frac{8}{2}</math>  <math>4 + 5(6) + 4</math>  <math>4 + 30 + 4</math>  <math>34 + 4</math> <span style="border: 1px solid red; padding: 2px;">38</span></p>
<p>3. <math>-9(4 + 2) - 2(3) + 4^2</math>  <math>-9(6) - 6 + 16</math>  <math>-54 - 6 + 16</math>  <math>-60 + 16</math>  <span style="border: 1px solid red; padding: 2px;">-44</span></p>	<p>4. <math>7 - 2[-6 - (3 + 1)] - \frac{8+7}{3}</math>  <math>7 - 2[-6 - 4] - \frac{15}{3}</math>  <math>7 - 2[-10] - 5</math>  <math>7 + 20 - 5</math>  <math>27 - 5</math> <span style="border: 1px solid red; padding: 2px;">22</span></p>
<p>5. <math>0.5(-8 - 4) + 3(8 - 2^2)</math>  <math>0.5(-12) + 3(8 - 4)</math>  <math>0.5(-12) + 3(4)</math>  <math>-6 + 12</math>  <span style="border: 1px solid red; padding: 2px;">6</span></p>	<p>6. <math>3 - 5(2) - 7(5^2 - 4^2)</math>  <math>3 - 10 - 7(25 - 16)</math>  <math>3 - 10 - 7(9)</math>  <math>3 - 10 - 63</math>  <math>-7 - 63</math> <span style="border: 1px solid red; padding: 2px;">-70</span></p>
<p>7. <math>2(3)^2 - 4(3) + 1</math>  <math>2(9) - 12 + 1</math>  <math>18 - 12 + 1</math>  <math>6 + 1</math>  <span style="border: 1px solid red; padding: 2px;">7</span></p>	<p>8. <math>4(3 - 5)^3 + 5</math>  <math>4(-2)^3 + 5</math>  <math>4(-8) + 5</math>  <math>-32 + 5</math>  <span style="border: 1px solid red; padding: 2px;">-27</span></p>

# THE NUMBER PROPERTIES

Match each expression with the property that it shows.

$$5 + 0 = 5$$

$$5(1) = 5$$

$$5(0) = 0$$

$$2 + 3 = 3 + 2$$

$$2(3) = 3(2)$$

$$2 + (3 + 4) = (2 + 3) + 4$$

$$2(3 \cdot 4) = (2 \cdot 3)4$$

$$3(2 + 5) = 6 + 15$$

Commutative Property  
of Addition

Associative Property  
of Addition

Additive Identity

Distributive Property

Commutative Property  
of Multiplication

Associative Property  
of Multiplication

Zero Product Property

Multiplicative Identity

## EVALUATING EXPRESSIONS

Evaluate each expression given the following values for each variable.

$a = 2$	$b = -3$	$c = 4$	$d = -5$	$e = 6$	$f = -7$
---------	----------	---------	----------	---------	----------

<p>1. <math>2a + 3d</math>  <math>2(2) + 3(-5)</math>  <math>4 + 3(-5)</math>  <math>4 - 15</math>  <span style="border: 1px solid red; padding: 2px;">-11</span></p>	<p>2. <math>b^2 - e^2</math>  <math>(-3)^2 - (6)^2</math>  <math>9 - 36</math>  <span style="border: 1px solid red; padding: 2px;">-27</span></p>
<p>3. <math>-3c - (a + d) + f</math>  <math>-3(4) - [2 + (-5)] + (-7)</math>  <math>-12 - [-3] - 7</math>  <math>-12 + 3 - 7</math>  <math>-9 - 7</math>  <span style="border: 1px solid red; padding: 2px;">-16</span></p>	<p>4. <math>2(b - e) + (f + c)^2</math>  <math>2(-3 - 6) + (-7 + 4)^2</math>  <math>2(-9) + (-3)^2</math>  <math>-18 + 9</math>  <span style="border: 1px solid red; padding: 2px;">-9</span></p>
<p>5. <math>\frac{d - c}{3} - 4(ab + f)</math>  <math>\frac{-5 - 4}{3} - 4[2(-3) + (-7)]</math>  <math>\frac{-9}{3} - 4[-6 - 7]</math>  <math>-3 - 4[-13]</math>  <math>-3 + 52</math>  <span style="border: 1px solid red; padding: 2px;">49</span></p>	<p>6. <math>c(ab - 1) + de - f^2</math>  <math>4[(2)(-3) - 1] + (-5)(6) - (-7)^2</math>  <math>4[-6 - 1] - 30 - 49</math>  <math>4[-7] - 30 - 49</math>  <math>-28 - 30 - 49</math>  <math>-58 - 49</math>  <span style="border: 1px solid red; padding: 2px;">-107</span></p>

# ADDING & SUBTRACTING FRACTIONS

Add or subtract the fractions. Simplify your answer.

$$\frac{1}{2} + \frac{1}{2} = \frac{2}{2} = 1$$

$$\frac{1}{3} + \frac{1}{3} = \frac{2}{3}$$

$$\frac{1}{4} + \frac{2}{4} = \frac{3}{4}$$

$$\frac{2}{5} - \frac{1}{5} = \frac{1}{5}$$

$$\frac{3}{6} - \frac{5}{6} = -\frac{2}{6} = -\frac{1}{3}$$

$$\frac{1}{7} - \frac{8}{7} = -\frac{7}{7} = -1$$

$$\frac{5}{8} - \frac{7}{8} = -\frac{2}{8} = -\frac{1}{4}$$

$$-\frac{5}{9} - \frac{1}{9} = -\frac{6}{9} = -\frac{2}{3}$$

$$-\frac{3}{10} + \frac{7}{10} = \frac{4}{10} = \frac{2}{5}$$

$$\begin{aligned} \frac{1}{2} + \frac{5}{4} &= \frac{2}{4} + \frac{5}{4} \\ &= \frac{7}{4} \end{aligned}$$

$$\begin{aligned} \frac{2}{9} + \frac{1}{3} &= \frac{2}{9} + \frac{3}{9} \\ &= \frac{5}{9} \end{aligned}$$

$$\begin{aligned} \frac{1}{4} + \frac{2}{16} &= \frac{4}{16} + \frac{3}{16} \\ &= \frac{7}{16} \end{aligned}$$

$$\begin{aligned} \frac{2}{3} - \frac{1}{5} &= \frac{10}{15} - \frac{3}{15} \\ &= \frac{7}{15} \end{aligned}$$

$$\begin{aligned} \frac{3}{6} - \frac{5}{4} &= \frac{6}{12} - \frac{15}{12} \\ &= -\frac{9}{12} = -\frac{3}{4} \end{aligned}$$

$$\begin{aligned} \frac{1}{2} - \frac{8}{7} &= \frac{7}{14} - \frac{16}{14} \\ &= -\frac{9}{14} \end{aligned}$$

$$\begin{aligned} \frac{5}{8} - \frac{7}{5} &= \frac{25}{40} - \frac{56}{40} \\ &= -\frac{31}{40} \end{aligned}$$

$$\begin{aligned} -\frac{5}{4} - \frac{1}{9} &= -\frac{45}{36} - \frac{4}{36} \\ &= -\frac{49}{36} \end{aligned}$$

$$\begin{aligned} -\frac{3}{10} + \frac{7}{3} &= -\frac{9}{30} - \frac{70}{30} \\ &= -\frac{79}{30} \end{aligned}$$

# MULTIPLYING & DIVIDING FRACTIONS

Multiply or divide the fractions. Simplify your answer.

$$\frac{5}{2} \cdot \frac{1}{2} = \frac{5}{4}$$

$$\frac{1}{3} \cdot \frac{1}{3} = \frac{1}{9}$$

$$\frac{1}{4} \cdot \frac{2}{4} = \frac{2}{16} = \frac{1}{8}$$

$$-\frac{2}{5} \cdot \frac{3}{5} = -\frac{6}{25}$$

$$\frac{3}{6} \cdot -\frac{5}{6} = -\frac{15}{36}$$

$$-\frac{1}{4} \cdot -\frac{8}{7} = -\frac{8}{28} = -\frac{2}{7}$$

$$4\left(\frac{5}{8}\right) = \frac{20}{8} = \frac{5}{2}$$

$$-3\left(\frac{2}{3}\right) = -\frac{6}{3} = -2$$

$$-2\left(\frac{4}{9}\right) = -\frac{8}{9}$$

$$\begin{aligned} \frac{1}{2} \div \frac{5}{4} &= \frac{1}{2} \cdot \frac{4}{5} \\ &= \frac{4}{10} = \frac{2}{5} \end{aligned}$$

$$\begin{aligned} \frac{2}{9} \div \frac{1}{3} &= \frac{2}{9} \cdot \frac{3}{1} \\ &= \frac{6}{9} = \frac{2}{3} \end{aligned}$$

$$\begin{aligned} \frac{1}{4} \div \frac{2}{5} &= \frac{1}{4} \cdot \frac{5}{2} \\ &= \frac{5}{8} \end{aligned}$$

$$\begin{aligned} -\frac{2}{3} \div \frac{1}{5} &= -\frac{2}{3} \cdot \frac{5}{1} \\ &= -\frac{10}{3} \end{aligned}$$

$$\begin{aligned} \frac{3}{6} \div -\frac{5}{4} &= \frac{3}{6} \cdot -\frac{4}{5} \\ &= -\frac{12}{30} = -\frac{2}{5} \end{aligned}$$

$$\begin{aligned} -\frac{1}{2} \div -\frac{8}{7} &= -\frac{1}{2} \cdot -\frac{7}{8} \\ &= \frac{7}{16} \end{aligned}$$

# COMBINING LIKE TERMS

Combine like terms for each expression.

EXPRESSION	SIMPLIFIED
$x + x + 3x + y$	$5x + y$
$y + 2y + 5x + x$	$6x + 3y$
$5 + z + z + 4z - 6$	$6z - 1$
$3x + 4x - 5$	$7x - 5$
$5c + 2b - 3c$	$2b + 2c$
$x + y + 2x$	$3x + y$
$6a - 5b + a$	$7a - 5b$
$4 + 3x - 7 - 8x$	$-5x - 3$
$3(x + 2) - 4$	$3x + 2$
$-5(x - 3) + 7x$	$2x + 15$
$5m - 6n - 9m$	$-4m - 6n$
$-8a - 9b - 10a + 9b$	$-18a$
$2(x + 4) + 5x - 3$	$7x + 5$
$-10(2 + x) - 3x$	$-13x - 20$

## SOLVING ONE-STEP EQUATIONS

Solve the one-step equations.

$$\begin{array}{r} x + 7 = 9 \\ -7 \quad -7 \\ \hline x = 2 \end{array}$$

$$\begin{array}{r} 5 + x = -3 \\ -5 \quad -5 \\ \hline x = -8 \end{array}$$

$$\begin{array}{r} 6 = x + 8 \\ -8 \quad -8 \\ \hline -2 = x \end{array}$$

$$\begin{array}{r} x - 9 = 1 \\ +9 \quad +9 \\ \hline x = 10 \end{array}$$

$$\begin{array}{r} -5 + x = -2 \\ +5 \quad +5 \\ \hline x = 3 \end{array}$$

$$\begin{array}{r} 4 = x - 7 \\ +7 \quad +7 \\ \hline 11 = x \end{array}$$

$$\begin{array}{r} 5x = 75 \\ 5 \quad 5 \\ \hline x = 15 \end{array}$$

$$\begin{array}{r} -2x = -64 \\ -2 \quad -2 \\ \hline x = 32 \end{array}$$

$$\begin{array}{r} -7.5 = 1.25x \\ -1.25 \quad -1.25 \\ \hline -6 = x \end{array}$$

$$\begin{array}{r} (4) \frac{x}{4} = 7 (4) \\ \hline x = 28 \end{array}$$

$$\begin{array}{r} (-2) -\frac{x}{2} = 8 (-2) \\ \hline x = -16 \end{array}$$

$$\begin{array}{r} (-9) -3 = -\frac{x}{9} (-9) \\ \hline 27 = x \end{array}$$

$$\begin{array}{r} (\frac{4}{3}) \frac{3}{4}x = 7 (\frac{4}{3}) \\ \hline x = \frac{28}{3} \end{array}$$

$$\begin{array}{r} (-\frac{2}{1}) -\frac{1}{2}x = 8 (-\frac{2}{1}) \\ \hline x = -16 \end{array}$$

$$\begin{array}{r} (-\frac{9}{2}) -5 = -\frac{2}{9}x (-\frac{9}{2}) \\ \hline \frac{45}{2} = x \end{array}$$

## SOLVING TWO-STEP EQUATIONS

Solve the two-step equations. Leave your answer as a simplified fraction.

$$2x + 7 = 9$$

$$\begin{array}{r} 2x + 7 = 9 \\ -7 \quad -7 \\ \hline 2x = 2 \\ \frac{2x}{2} = \frac{2}{2} \end{array}$$

$$x = 1$$

$$5 + 4x = -3$$

$$\begin{array}{r} 5 + 4x = -3 \\ -5 \quad -5 \\ \hline 4x = -8 \\ \frac{4x}{4} = \frac{-8}{4} \end{array}$$

$$x = -2$$

$$6 = 2x + 8$$

$$\begin{array}{r} 6 = 2x + 8 \\ -8 \quad -8 \\ \hline -2 = 2x \\ \frac{-2}{2} = \frac{2x}{2} \end{array}$$

$$-1 = x$$

$$4x - 9 = 1$$

$$\begin{array}{r} 4x - 9 = 1 \\ +9 \quad +9 \\ \hline 4x = 10 \\ \frac{4x}{4} = \frac{10}{4} \end{array}$$

$$x = 2.5$$

$$-5 + 3x = -2$$

$$\begin{array}{r} -5 + 3x = -2 \\ +5 \quad +5 \\ \hline 3x = 3 \\ \frac{3x}{3} = \frac{3}{3} \end{array}$$

$$x = 1$$

$$4 = -x - 7$$

$$\begin{array}{r} 4 = -x - 7 \\ +7 \quad +7 \\ \hline 11 = -x \\ \frac{11}{-1} = \frac{-x}{-1} \end{array}$$

$$-11 = x$$

$$5x + 10 = 75$$

$$\begin{array}{r} 5x + 10 = 75 \\ -10 \quad -10 \\ \hline 5x = 65 \\ \frac{5x}{5} = \frac{65}{5} \end{array}$$

$$x = 13$$

$$-2x + 8 = -64$$

$$\begin{array}{r} -2x + 8 = -64 \\ -8 \quad -8 \\ \hline -2x = -72 \\ \frac{-2x}{-2} = \frac{-72}{-2} \end{array}$$

$$x = 36$$

$$-7.5 = 1.25x + 2.5$$

$$\begin{array}{r} -7.5 = 1.25x + 2.5 \\ -2.5 \quad -2.5 \\ \hline -10 = 1.25x \\ \frac{-10}{1.25} = \frac{1.25x}{1.25} \end{array}$$

$$-8 = x$$

$$\frac{x}{4} - 6 = 7$$

$$\begin{array}{r} \frac{x}{4} - 6 = 7 \\ +6 \quad +6 \\ \hline \frac{x}{4} = 13 \end{array}$$

$$x = 52$$

$$-\frac{x}{2} + 3 = 8$$

$$\begin{array}{r} -\frac{x}{2} + 3 = 8 \\ -3 \quad -3 \\ \hline -\frac{x}{2} = 5 \end{array}$$

$$x = -10$$

$$-3 = 8 - \frac{x}{9}$$

$$\begin{array}{r} -3 = 8 - \frac{x}{9} \\ -8 \quad -8 \\ \hline -11 = -\frac{x}{9} \end{array}$$

$$99 = x$$

$$\frac{3}{4}x + 5 = 7$$

$$\begin{array}{r} \frac{3}{4}x + 5 = 7 \\ -5 \quad -5 \\ \hline \frac{3}{4}x = 2 \end{array}$$

$$x = \frac{8}{3}$$

$$-\frac{1}{2}x - 4 = 8$$

$$\begin{array}{r} -\frac{1}{2}x - 4 = 8 \\ +4 \quad +4 \\ \hline -\frac{1}{2}x = 12 \end{array}$$

$$x = -24$$

$$-5 = -\frac{2}{9}x + 2$$

$$\begin{array}{r} -5 = -\frac{2}{9}x + 2 \\ -2 \quad -2 \\ \hline -7 = -\frac{2}{9}x \end{array}$$

$$31.5 = x$$



# ANSWER KEY

# RATIOS

Create the ratios for each situation.

To create a perfect fruit smoothie for you and your friends, you must use 5 strawberries, 9 blueberries, 1 banana, 4 slices of pineapple, and 3 slices of mango.

FRUIT	RATIO
strawberries to blueberries	5:9
strawberries to pineapple	5:4
pineapple to mango	4:3
mango to banana	3:1 or 3
banana to blueberries	1:9
mango to blueberries	3:9 → 1:3
pineapple to berries	4:14 → 2:7
mango to the smoothie	3:22
pineapple to the smoothie	4:22 → 2:11
berries to the smoothie	14:22 → 7:11
berries to non-berries	14:8 → 7:4
smoothie to blueberries	22:9
smoothie to mango	22:3

# SOLVING PROPORTIONS

Solve each proportion. Leave your answer as a simplified fraction or decimal.

$$\frac{x}{3} = \frac{4}{6}$$

$$x(6) = 3(4)$$

$$6x = 12$$

$$x = 2$$

$$\frac{6}{5} = \frac{x}{4}$$

$$6(4) = 5(x)$$

$$24 = 5x$$

$$4.8 = x$$

$$\frac{3}{5} = \frac{6}{x}$$

$$3(x) = 5(6)$$

$$3x = 30$$

$$x = 10$$

$$\frac{x}{7} = \frac{1}{6}$$

$$x(6) = 7(1)$$

$$6x = 7$$

$$x = \frac{7}{6}$$

$$\frac{6}{x} = \frac{2.5}{2}$$

$$6(2) = x(2.5)$$

$$12 = 2.5x$$

$$4.8 = x$$

$$\frac{4.5}{3} = \frac{9}{x}$$

$$4.5(x) = 3(9)$$

$$4.5x = 27$$

$$x = 6$$

$$\frac{x}{3} = \frac{4.2}{10}$$

$$x(10) = 3(4.2)$$

$$10x = 12.6$$

$$x = 1.26$$

$$\frac{11}{x} = \frac{2.5}{5.5}$$

$$11(5.5) = x(2.5)$$

$$60.5 = 2.5x$$

$$24.2 = x$$

$$\frac{6}{5} = \frac{12}{x}$$

$$6(x) = 5(12)$$

$$6x = 60$$

$$x = 10$$

# GRAPHING INEQUALITIES

Graph each inequality on the number line shown.

$x > 2$

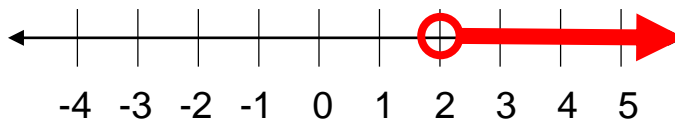

$x < -3$

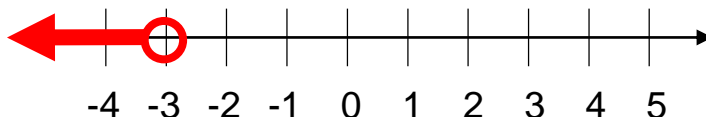

$x \geq -1$

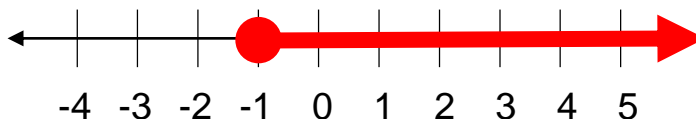

$x \leq 4$

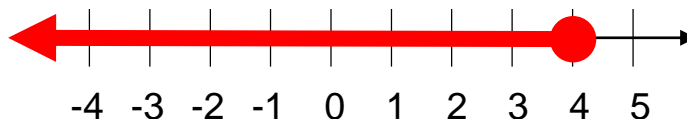

$x < 0$

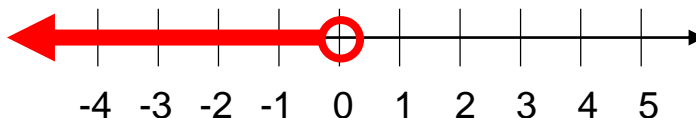

$x \geq 0$

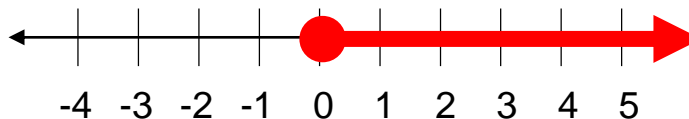

$x > -2$

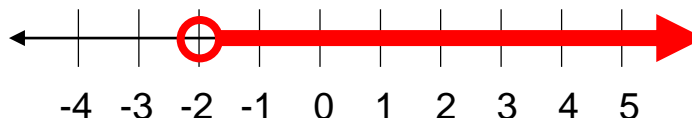

# THE COORDINATE PLANE

Plot each point on the coordinate plane and name the quadrant the point is in.

POINT	QUADRANT
A(3, 4)	I
B(5, -7)	IV
C(0, -5)	y-axis
D(-9, 2)	II

POINT	QUADRANT
E(-1, -2)	III
F(-8, 0)	x-axis
G(10, 3)	I
H(-4, 8)	II

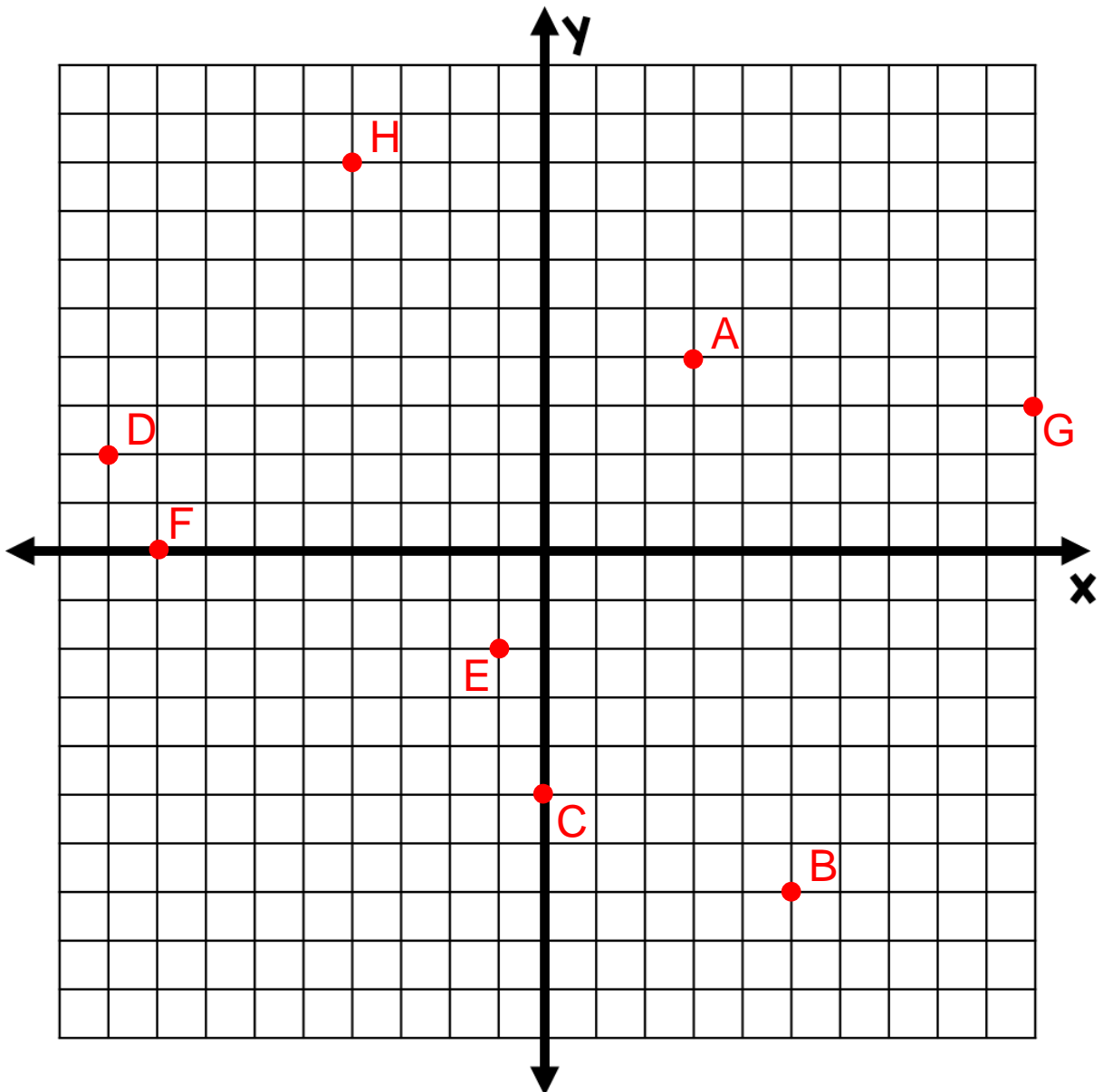

# GRAPHING BY MAKING A TABLE

Graph the equations by using substitution to complete a table of values.

$$y = x + 2$$

x	y
-2	0
-1	1
0	2
1	3
2	4

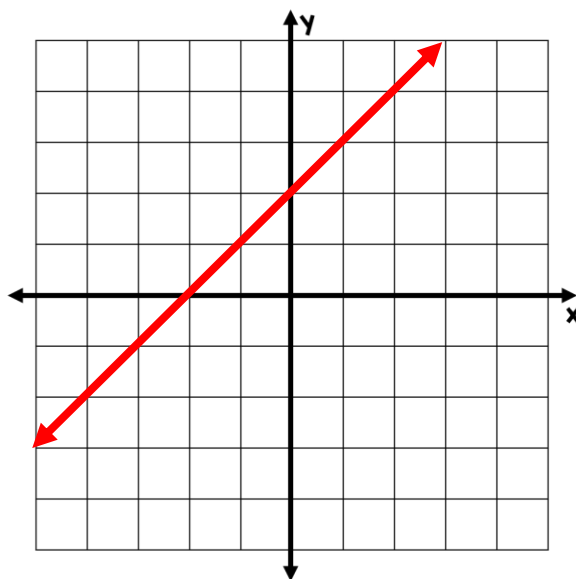

$$y = 2x - 1$$

x	y
-2	-5
-1	-3
0	-1
1	1
2	3

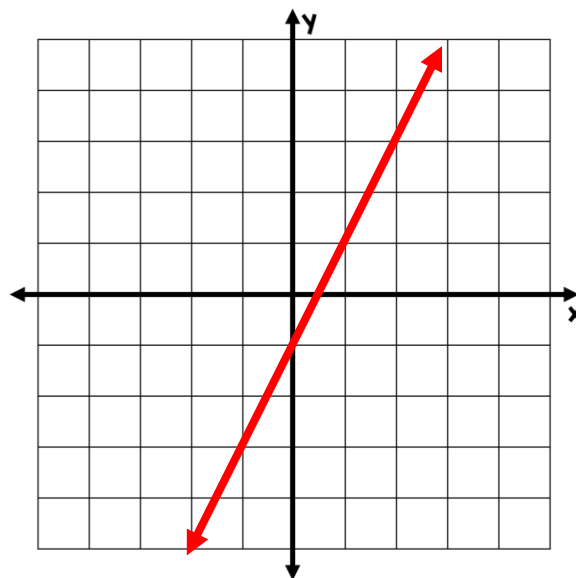

# SLOPE & y-INTERCEPT

Determine the slope and the y-intercept of each graph.

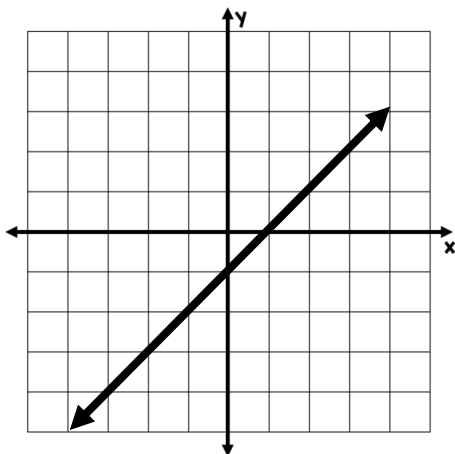

slope:	1
y-intercept:	-1

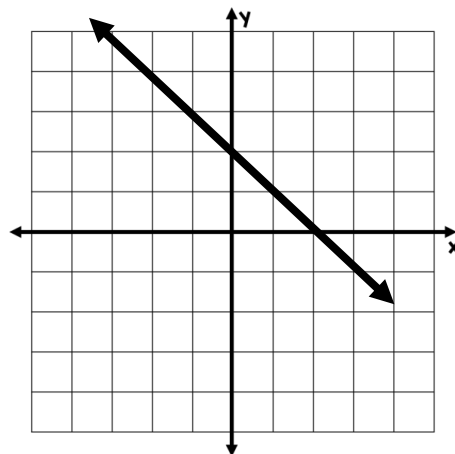

slope:	-1
y-intercept:	2

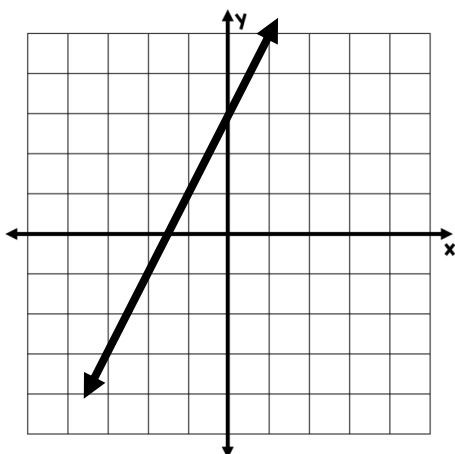

slope:	2
y-intercept:	3

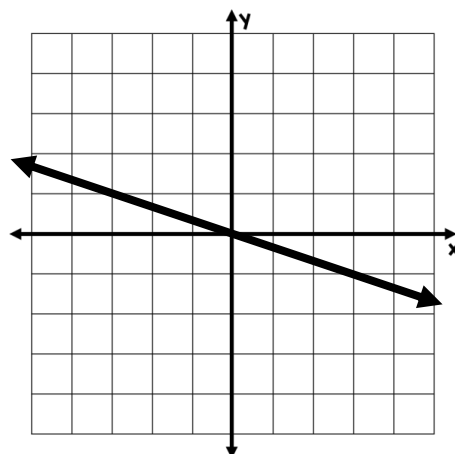

slope:	$-\frac{1}{3}$
y-intercept:	0

# BASIC EXPONENT RULES

Simplify each expression using exponent rules.

EXPRESSION	SIMPLIFIED
$x \cdot x$	$x^2$
$y \cdot y \cdot y \cdot y$	$y^4$
$x \cdot x \cdot y \cdot y \cdot y$	$x^2y^3$
$y \cdot z \cdot z \cdot z \cdot z \cdot z$	$yz^5$
$x^2 \cdot x^3$	$x^5$
$x^5 \cdot x^4$	$x^9$
$y^6 \cdot y$	$y^7$
$(x^4)^3$	$x^{12}$
$(y^3)^2$	$y^6$
$x^2 \cdot x \cdot y^3 \cdot y^4$	$x^3y^7$
$a^4 \cdot b^8 \cdot a^5 \cdot b^2$	$a^9b^{10}$
$c^3 \cdot d \cdot c^4 \cdot b$	$bc^7d$
$\frac{x^5}{x^2}$	$x^3$
$\frac{y^8}{y^3}$	$y^5$

# SEQUENCES & PATTERNS

Determine the pattern of each sequence and find the next 3 terms.

2, 4, 8, 16, 32, 64, 128, 256      multiply by 2

5, 10, 15, 20, 25, 30, 35, 40      add by 5

-5, -3, -1, 1, 3, 5, 7, 9      add by 2

0.4, 0.2, 0, -0.2, -0.4, -0.6, -0.8, -1      subtract  
by 0.2

3, -6, 12, -24, 48, -96, 192, -384      multiply by -2

$\frac{3}{9}$ ,  $\frac{4}{9}$ ,  $\frac{5}{9}$ ,  $\frac{6}{9}$ ,  $\frac{7}{9}$ ,  $\frac{8}{9}$ , 1,  $\frac{10}{9}$       add by  $\frac{1}{9}$

$\frac{1}{2}$ ,  $\frac{1}{4}$ ,  $\frac{1}{8}$ ,  $\frac{1}{16}$ ,  $\frac{1}{32}$ ,  $\frac{1}{64}$ ,  $\frac{1}{128}$ ,  $\frac{1}{256}$       multiply by  $\frac{1}{2}$

6, -3, -12, -21, -30, -39, -48, -57      subtract by 9

0.32, 0.8, 2, 5, 12.5, 31.25, 78.125, 195.3125      multiply  
by 2.5



# CALCULATING PERIMETER

Determine the perimeter of each figure.

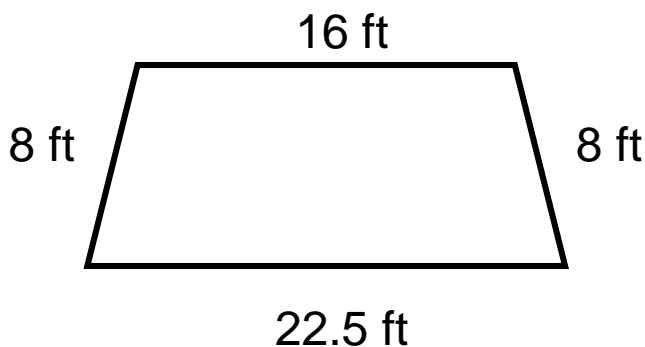

$$P = 16 + 8 + 22.5 + 8$$

$$P = 54.5 \text{ ft}$$

$$P = 5 + 2x + 2x + 5 + 3x$$

$$P = 7x + 10 \text{ cm}$$

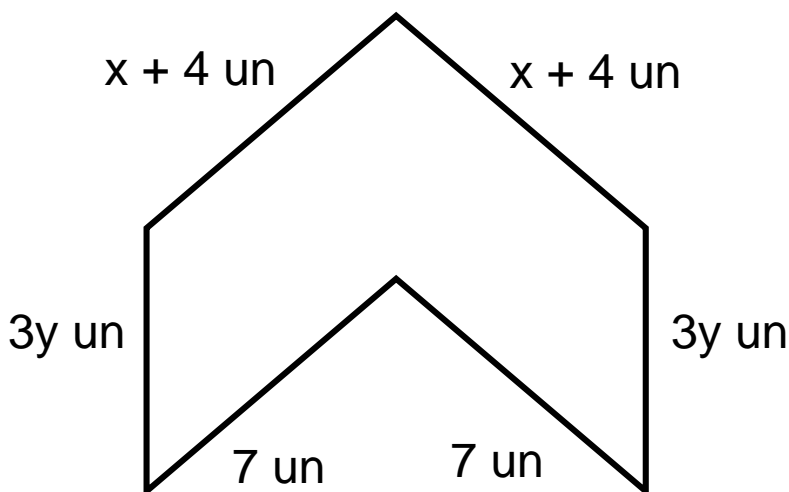
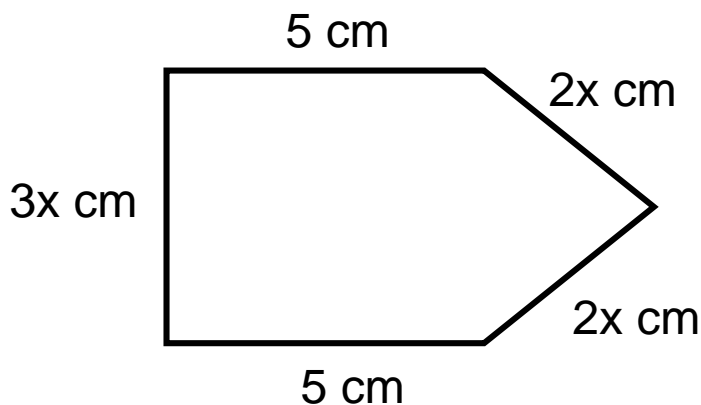

$$P = x + 4 + x + 4 + 3y + 3y + 7 + 7$$

$$P = 2x + 6y + 22 \text{ un}$$

# CALCULATING AREA

Determine the area of each figure.

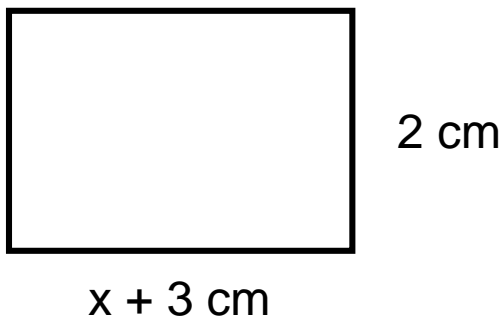

$$A = \text{length} \cdot \text{width}$$

$$A = (x + 3)2$$

$$A = 2x + 6 \text{ cm}^2$$

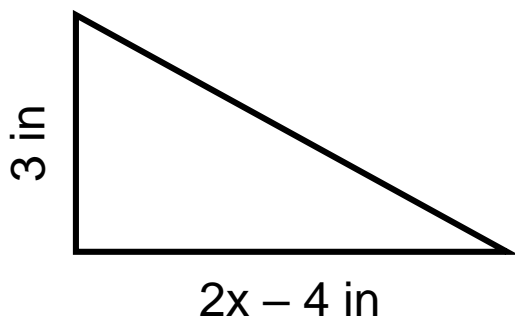

$$A = \frac{1}{2} \text{ base} \cdot \text{height}$$

$$A = \frac{1}{2}(2x - 4)(3)$$

$$A = \frac{1}{2}(2x - 4)(3)$$

$$A = 1.5(2x - 4)$$

$$A = 3x - 6 \text{ in}^2$$

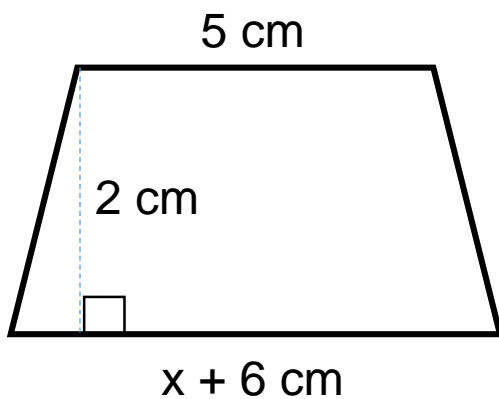

$$A = \frac{1}{2} \text{ height}(\text{base 1} + \text{base 2})$$

$$A = \frac{1}{2}(2)(5 + x + 6)$$

$$A = 5 + x + 6$$

$$A = x + 11 \text{ cm}^2$$

# PERFECT SQUARE NUMBERS

Complete the perfect squares chart. Fill in as many as you can without a calculator.

$1^2 =$	1	$16^2 =$	256
$2^2 =$	4	$17^2 =$	289
$3^2 =$	9	$18^2 =$	324
$4^2 =$	16	$19^2 =$	361
$5^2 =$	25	$20^2 =$	400
$6^2 =$	36	$21^2 =$	441
$7^2 =$	49	$22^2 =$	484
$8^2 =$	64	$23^2 =$	529
$9^2 =$	81	$24^2 =$	576
$10^2 =$	100	$25^2 =$	625
$11^2 =$	121	$30^2 =$	900
$12^2 =$	144	$40^2 =$	1600
$13^2 =$	169	$50^2 =$	2500
$14^2 =$	196	$60^2 =$	3600
$15^2 =$	225	$70^2 =$	4900